

SECOND LABORATORY

AMPLITUDE MODULATED SIGNALS WITH HARMONIC CARRIER SIGNAL

1. Objective of the laboratory

In this laboratory it will be analyzed the spectra of the amplitude modulated oscillations when sinusoidal, rectangular and triangular message signals are involved.

2. Theoretical aspects

A communication system with a transmitter and a receiver is considered. The information transmitted by the transmitter to the receiver will be further referred to as the “message”. The electrical signals corresponding to the messages can be transmitted directly, as they come from the source that generates them (e.g. sensors, signal generators, etc.), but in most cases this transmission has disadvantages, such as the fact that several signals which can be transmitted in the same time have overlapping spectra, the communication channel is disrupted in the frequency range where the message signals have important spectral components, the message signals have low frequency, etc. If the communication is wireless, radio type, the antenna size is directly proportional to the wavelength of the signal, this involves the use of a very large antenna to transmit low frequency signals (messages).

In the modulation process, there are involved three signals: the modulating signal (the message signal), the carrier signal and the modulated signal. By modulation, the characteristics of the signal corresponding to the message, also called the modulator signal, are transferred over a signal having the spectrum in the higher frequency range called the carried signal (or carrier wave), and the signal resulted from the modulation process is the modulated signal.

The use of the modulation attenuates or eliminates the disadvantages of the above mentioned direct transmission, for example: the frequencies in the spectrum of the carrier signal can be chosen so that the spectral domain of the modulated signal does not overlap the spectrum of the disturbances.

Amplitude modulated signals with harmonic carrier signal

The modulation process takes place in the transmission part of a communication system. At the reception, an inverse operation (demodulation) is performed, where the signal corresponding to the message is extracted from the received modulated signal.

The general expression of a modulated oscillation is:

$$x(t) = A(t) \cdot \cos \Phi(t), \quad (1)$$

in which $A(t)$ is the amplitude of the oscillation, $\Phi(t)$ is the phase angle and $\Omega_i(t) = \frac{d\Phi(t)}{dt}$ is the instantaneous frequency. In the absence of the modulation,

$$A(t) = \text{const.} = A_0,$$

$$\Omega_i(t) = \text{const.} = \Omega_0,$$

$$\Phi(t) = \int \Omega_i(t) dt + \phi_0 = \Omega_0 t + \Phi_0$$

and relation (1) is reduced to the expression of the carrier:

$$x_0(t) = A_0 \cos(\Omega_0 t + \Phi_0). \quad (1')$$

We will note with $x_m(t)$ the message signal. Usually, this is a signal with the maximum frequency in the spectrum, much lower than the frequency of the carrier signal, $\omega_{m,M} \ll \Omega_0$.

In the case of the amplitude modulated (AM) signal, the amplitude $A(t)$ of the modulated signal varies around the value of A_0 , in the rhythm of the message signal, and the frequency $\Omega_i(t)$ is constant and equal to Ω_0 , so:

$$A(t) = A_0 + K_A x_m(t),$$

and the amplitude modulated signal becomes:

$$x_{MA}(t) = [A_0 + K_A x_m(t)] \cos(\Omega_0 t + \Phi_0). \quad (2)$$

In the case of the harmonic message signal we have:

$$x_m(t) = A_m \cos(\omega_m t + \phi_m), \quad (3)$$

$$A(t) = A_0 + K_A A_m \cos(\omega_m t + \phi_m) = A_0 [1 + m \cos(\omega_m t + \phi_m)], \quad (4)$$

$$x_{MA}(t) = A_0 [1 + m \cos(\omega_m t + \phi_m)] \cos(\Omega_0 t + \phi_0). \quad (5)$$

Amplitude modulated signals with harmonic carrier signal

In the above relations, K_A is a specific constant of the amplitude modulator, and $m = K_A \cdot A_m / A_0$ is called the modulation index. Normally $m \in [0,1]$. If $m > 1$, $A(t)$ becomes at some point negative, which corresponds to a phase shift of 180° . In this case, we can say that the oscillation is overmodulated.

If in relation (5) the mathematic operations are done, and the cosine product is converted into a sum, the spectral development of the modulated signal is:

$$x_{MA}(t) = A_0 \cos(\Omega_0 t + \Phi_0) + \frac{m}{2} A_0 \cos[(\Omega_0 + \omega_m)t + \Phi_0 + \phi_m] + \frac{m}{2} A_0 \cos[(\Omega_0 - \omega_m)t + \Phi_0 - \phi_m]. \quad (6)$$

It is found that the amplitude spectrum of the AM signal contains three components: the unmodulated amplitude of the carrier signal, A_0 , and two side components, the upper one with the amplitude $A_1 = \frac{m}{2} \cdot A_0$, on the frequency $F_0 + f_m$, and lower one with the amplitude $A_{-1} = \frac{m}{2} \cdot A_0 = A_1$, on the frequency $F_0 - f_m$.

The amplitude and the phase spectra are represented in figure 1.

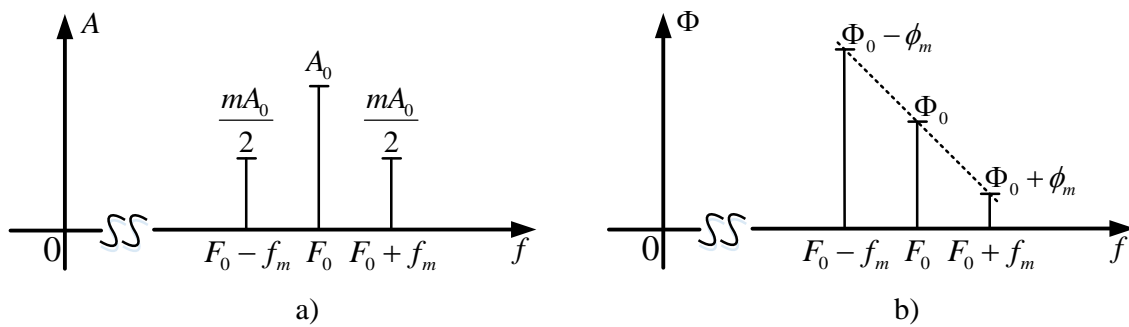

Figure 1. Amplitude and phase spectra of the AM signal with harmonic carrier signal and harmonic message signal

It is noted that the amplitude spectrum is symmetrical in relation to the carrier frequency, and the phase spectrum is asymmetric. For a convenient graphical representation, in case $F_0 \gg f_m$, the axis of the abscissa has not been drawn in the area where there are not any spectral components.

Amplitude modulated signals with harmonic carrier signal

The bandwidth occupied by the signal, in this case, is the range $[F_0 - f_m, F_0 + f_m]$ of width $B = 2f_m$ (double of the message signal frequency).

From the relation (5) the maximum and minimum values of the $A(t)$ oscillation amplitude are determined. These are obtained when $\cos(\omega_m t + \phi_m)$ is maximum (equal to 1) and, respectively, minimum (equal to -1): $A_{\max} = A_0 \cdot (1 + m)$ and $A_{\min} = A_0 \cdot (1 - m)$. It is necessary that the amplitudes remain always positive, $A_{\min} \geq 0$, to avoid overmodulation, meaning $m \leq 1$.

If A_{\max} and A_{\min} are known, the modulation index, m , can be determined using the expression:

$$m = \frac{A_{\max} - A_{\min}}{A_{\max} + A_{\min}}. \quad (7)$$

By visualizing the modulated signal with an oscilloscope (figure 2.a), with the relation (7) the modulation index can be determined. Also, the A_0 amplitude of the carried signal is obtained according to the relation:

$$A_0 = \frac{A_{\max} + A_{\min}}{2}. \quad (8)$$

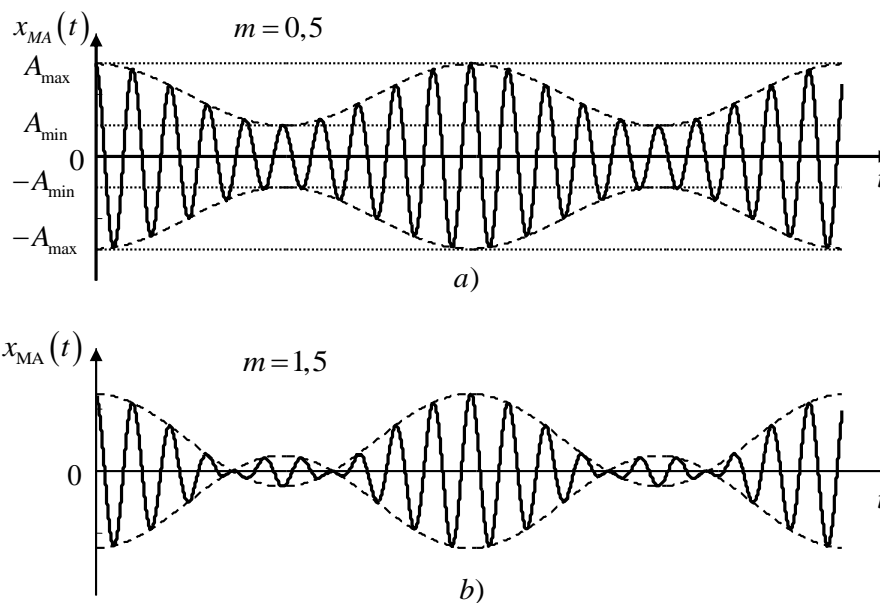

Figure 2. a) The representation in time domain of an AM signal with $m = 0,5$;
b) The representation in time domain of a modulated AM signal with $m = 1,5$.

Amplitude modulated signals with harmonic carrier signal

In figure 2.b) is presented the case of an amplitude modulated signal in which the oscillation is overmodulated, $m = 1,5$.

The dissipated power of the AM signal, with harmonic message signal, on a 1Ω resistor, as well as the effective value of this signal, calculated using the time domain (Table 2), have the following expressions:

$$P = \frac{A_0^2}{2} \left(1 + \frac{m^2}{2} \right), \quad (9)$$

$$X_{ef} = \sqrt{P}. \quad (10)$$

The useful power (corresponding to the message) is given by the dissipated power of the side components and has the expression:

$$P_u = \frac{A_0^2}{2} \cdot \frac{m^2}{2} = P_0 \frac{m^2}{2}. \quad (11)$$

Important note: in relations (9), (10) and (11) A_0 is calculated using relation (8), based on the measurements in the time domain (Table 2), and the value obtained is multiplied by the division coefficient θ , found in the last paper or redetermined in the current paper, before introducing (9), (10) and (11).

The homologous expressions to those given by the relations (9) and (10), using this time the frequency domain of the AM signal, with a harmonic message signal, are:

$$P = \frac{A_0^2}{2} + \frac{A_{-1}^2}{2} + \frac{A_1^2}{2} = A_{0,ef}^2 + A_{-1,ef}^2 + A_{1,ef}^2, \quad (12)$$

$$X_{ef} = \sqrt{P} = \sqrt{\frac{A_0^2}{2} + \frac{A_{-1}^2}{2} + \frac{A_1^2}{2}} = \sqrt{A_{0,ef}^2 + A_{-1,ef}^2 + A_{1,ef}^2}. \quad (13)$$

The useful power is given, in this case, by the relation:

$$P_u = \frac{A_{-1}^2}{2} + \frac{A_1^2}{2} = A_{-1,ef}^2 + A_{1,ef}^2. \quad (14)$$

In the case of a periodic message signal, without DC offset, the Harmonic Fourier series can be written as follows:

Amplitude modulated signals with harmonic carrier signal

$$x_m(t) = \sum_{k=1}^{\infty} A_k \cos(k\omega_0 t + \phi_k).$$

The bandwidth occupied by $x_m(t)$ is finite and, in this bandwidth, k_M components are included. Therefore:

$$x_m(t) \approx \sum_{k=1}^{k_M} A_k \cos(k\omega_0 t + \phi_k).$$

As a result, the relation (2) of the amplitude modulated signal becomes:

$$x_{MA}(t) = A_0 \left[1 + \frac{k_A}{A_0} \sum_{k=1}^{k_M} A_k \cos(k\omega_0 t + \phi_k) \right] \cos(\Omega_0 t + \Phi_0),$$

$$\begin{aligned} x_{MA}(t) &= A_0 \cos(\Omega_0 t + \Phi_0) + \sum_{k=1}^{k_M} \frac{m_k A_0}{2} \cos[(\Omega_0 + k\omega_0)t + \Phi_0 + \phi_k] + \\ &\quad + \sum_{k=1}^{k_M} \frac{m_k A_0}{2} \cos[(\Omega_0 - k\omega_0)t + \Phi_0 - \phi_k], \end{aligned}$$

where $m_k = \frac{k_A \cdot A_k}{A_0}$ represents the partial modulation indices.

The dissipated power of the AM signal, with a modulation signal composed by a sum of harmonic oscillations, on a 1Ω resistance, as well as the effective value of this signal, have the expressions:

$$P = \frac{A_0^2}{2} \left(1 + \sum_{k=1}^{k_M} \frac{m_k^2}{2} \right) = P_0 \left(1 + \sum_{k=1}^{k_M} \frac{m_k^2}{2} \right), \quad (15)$$

$$X_{ef} = \frac{A_0}{\sqrt{2}} \sqrt{1 + \sum_{k=1}^{k_M} \frac{m_k^2}{2}}. \quad (16)$$

The useful power is given by the relation:

$$P_u = \frac{A_0^2}{2} \sum_{k=1}^{k_M} \frac{m_k^2}{2} = P_0 \sum_{k=1}^{k_M} \frac{m_k^2}{2}. \quad (17)$$

The homologous expressions to those given by the relations (15) and (16), using this time the frequency domain of the AM signal, with a message signal composed by a sum of harmonic oscillations, are:

Amplitude modulated signals with harmonic carrier signal

$$P = \frac{A_0^2}{2} + \sum_{k=1}^{k_M} \frac{A_{-k}^2}{2} + \sum_{k=1}^{k_M} \frac{A_k^2}{2} = A_{0,ef}^2 + \sum_{k=1}^{k_M} A_{-k,ef}^2 + \sum_{k=1}^{k_M} A_{k,ef}^2, \quad (18)$$

$$X_{ef} = \sqrt{P} = \sqrt{\frac{A_0^2}{2} + \sum_{k=1}^{k_M} \frac{A_{-k}^2}{2} + \sum_{k=1}^{k_M} \frac{A_k^2}{2}} = \sqrt{A_{0,ef}^2 + \sum_{k=1}^{k_M} A_{-k,ef}^2 + \sum_{k=1}^{k_M} A_{k,ef}^2}. \quad (19)$$

The useful power is calculated in this case with the relation:

$$P_u = P - P_0 = \sum_{k=1}^{k_M} \frac{A_{-k}^2}{2} + \sum_{k=1}^{k_M} \frac{A_k^2}{2} = \sum_{k=1}^{k_M} A_{-k,ef}^2 + \sum_{k=1}^{k_M} A_{k,ef}^2. \quad (20)$$

The amplitude spectrum of the periodic message signal is represented in figure 3.a), and the amplitude spectrum of the AM signal in figure 3.b).

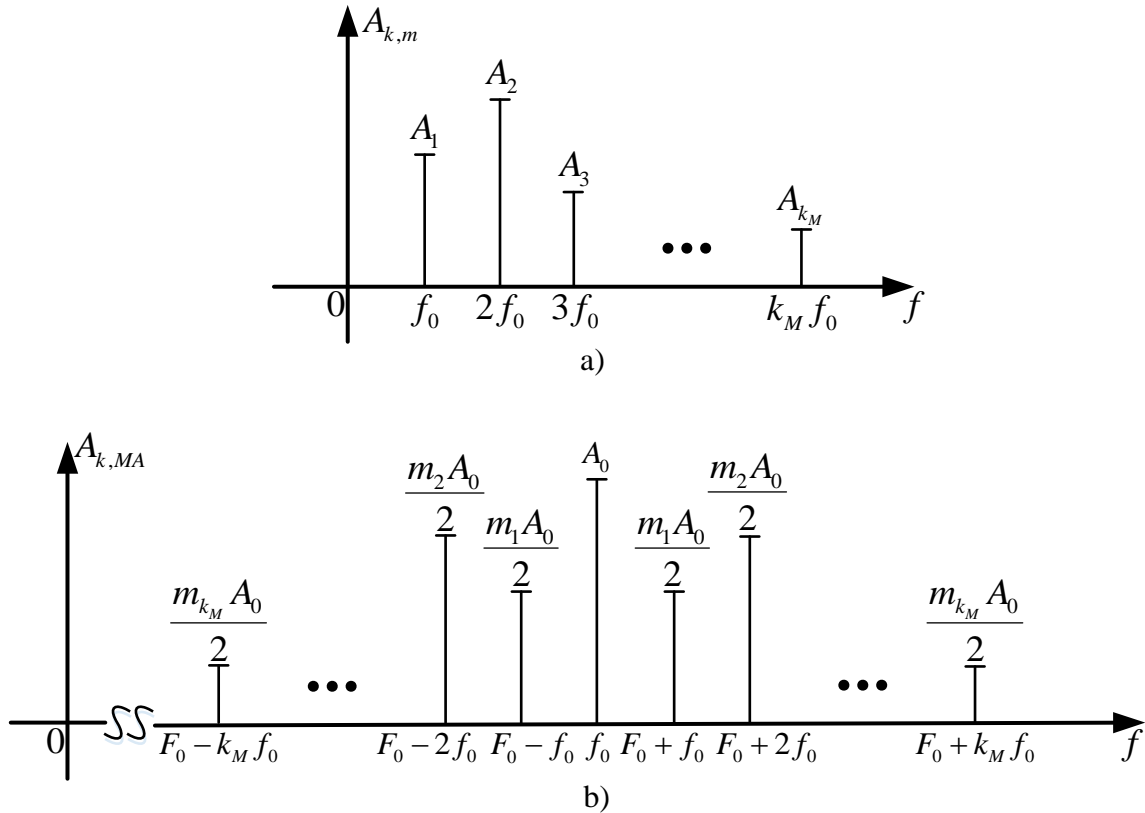

Figure 3. a) The amplitude spectrum of the periodic message signal;
b) The amplitude spectrum of the $x_{MA}(t)$ signal for a periodic message signal.

The bandwidth occupied by the signal is in the range $[F_0 - k_M f_0, F_0 + k_M f_0]$, of width $B = 2k_M f_0$.

3. Practical part

The connections from figure 4 are realized.

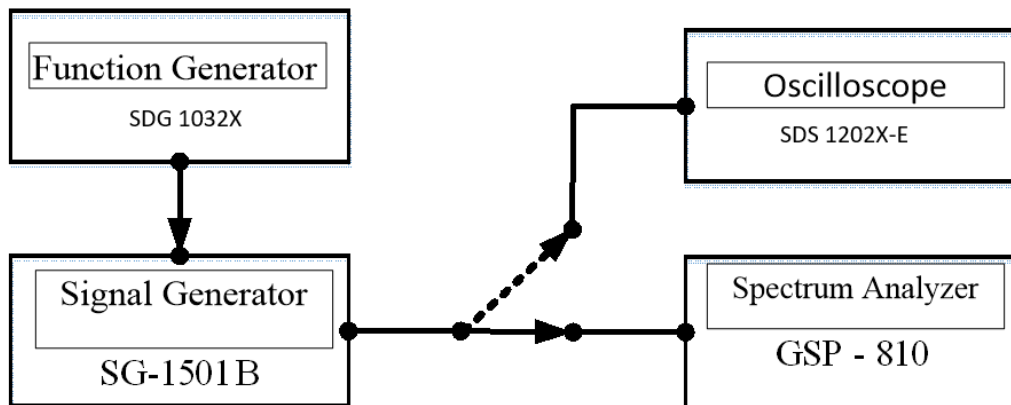

Figure 4. The measurement scheme used in the laboratory.

A) Determination of the modulation index using spectral measurements

The function generator is reset by pressing Shift+RS232. Connect the main output (MAIN) of the function generator to the input of the modulated signal generator (EXT INPUT AF/L). Connect the output of the modulated signal generator (OUTPUT) to the spectral analyzer input (RF INPUT 50Ω).

Set the message signal parameters from the function generator: sinusoidal waveform (Waveforms button and then the first button on the left below the screen corresponding to the sinusoidal waveform), adjust its frequency to 5 kHz (the first button on the left below the screen is pressed until Frequency is selected with blue, then on the keyboard press 5 and from the buttons below the display the measurement unit kHz). The effective value is a parameter that will be varied within the experiment (by changing the value indicated by Amplitude).

The parameters of the carrier signal and of the modulation process are adjusted as follows: proceed in such way that in the MODULATION button grouping only the AM and EXT buttons are activated (indicative LEDs on). Adjust the carrier frequency as follows: press the FREQ button in the DATA ENTRY button grouping (note, the FREQ button of the modulated signal generator, not of the function generator!), enter the value 500 using the adjacent numeric keys and press the kHz key. The carrier frequency is set to 500 kHz, and on the FREQUENCY display will be found the value 0.500.0 MHz, the first point is playing the role of the decimal point, and the second point is only a

Amplitude modulated signals with harmonic carrier signal decimal separator used for making the reading easier. Rigorously, the display number is 0,500.0. Adjust the modulation index to 20% as follows: press the MOD button (below the previously used FREQ button), enter the value 20 using the same keyboard as in the previous operation and press the ENT button that should have the LED on. After pressing, the LED will go off and the entered modulation index (20.0) can be read on the EXT MODULATION display found on the left of the FREQUENCY display. Attention, the modulation index depends on the amplitude of the message signal by $m = K_A \cdot A_m / A_0$. The device guarantees that the introduced modulation index will be obtained if the input signal has an effective value of 1 V.

Adjust the parameters of the spectrum analyzer as follows: centre is set at the frequency of the carrier signal (500 kHz) by pressing the CENTER button, entering the value 0.5 and pressing the MHz button. Adjust the SPAN parameter to 5 kHz/div by pressing the SPAN button and using the rotary knob to select the desired value of the possible ones. Adjust the reference level to 10 dBm by pressing the REF LVL button and using the rotary knob to select the desired value of the possible ones.

It is desired the adjustment of the carrier component level to 0 dBm. To do this, the carrier is measured with a cursor by pressing the MKR button, entering the value 0.5 and pressing the MHz button. The level of the carrier component is modified from the modulated signal generator until it becomes 0 dBm, measured with the spectral analyzer (attention, not displayed on the modulated signal generator, but measured with the analyzer!) in the following way: underneath one of the digits displayed on a display (EXT MODULATION, FREQUENCY or OUTPUT LEVEL) a green LED will light up to indicate that the digit is selected. This LED will be moved in the OUTPUT LEVEL display by repeatedly pressing a double arrow (for example ►►). Then, select the least significant digit on that display by repeatedly pressing the single arrow (for example ►). Use the rotary knob underneath the arrow group to change the carrier level. Turn this knob until a level of 0 dBm is measured for the carrier component on the spectrum analyzer. (Because the input impedance in spectrum analyzers is no longer 50 Ω, the value displayed on the OUTPUT LEVEL

Amplitude modulated signals with harmonic carrier signal display of the modulated signal generator will probably differ from 0 dBm, generally being higher).

The division factor θ can now be determined as follows:

$$\theta = \frac{0.2236 \cdot 10^{\frac{-OUTPUT LEVEL}{20}}}{2 \cdot 0.2236}$$

Measure the level of the spectral components of the modulated signal A_0 , A_1 and A_{-1} using the spectral analyzer for each effective value of the message signal indicated in the table. For the first measurement, proceed as follows: adjust the effective value of the message signal by pressing the button which is corresponding to Amplitude of the function generator (second button below of the function generator screen, from left to right), until Amplitude is selected with blue, entering the value 0.3 and pressing the kHz/ V_{rms} button. Measure the level of the A_{-1} spectral component with the spectral analyzer by pressing the MKR button, entering the value 0.495 and pressing of the MHz button. Write the measured value in Table 1 (attention to take in consideration the sign, + or -, displayed on the analyzer). The procedure is similar for A_0 at the 500 kHz frequency, respectively for A_1 at the 505 kHz frequency. The measured values are effective values!

The effective values (in volts) are determined for each spectral component (the reference voltage used is 0.2236 V) and written in Table 1. All measured values, written in Table 1, are effective values (the analyzer measures the effective values of the components)!

Table 1. Spectral determination of the modulation index for the AM signal

$A_{M,ef}$ [V]	$A_{0,ef}$ [dBm]	$A_{1,ef}$ [dBm]	$A_{-1,ef}$ [dBm]	$A_{0,ef}$ [V]	$A_{1,ef}$ [V]	$A_{-1,ef}$ [V]	m_1	m_{-1}
0,3								
0,5								
0,7								
0,9								

The m_1 and m_{-1} are calculated using the formula:

Amplitude modulated signals with harmonic carrier signal

$$A_{k,ef} = \frac{m \cdot A_{0,ef}}{2}, k = \{-1,1\}.$$

B) Determination of the modulation index using measurements in time domain

Connect the output of the modulated signal generator (OUTPUT) to the input of the channel 2 of the oscilloscope (CH 2). Adjust the smallest effective value of the message signal by pressing the AMPL button of the function generator, then enter the value 0.3 and press kHz/V_{rms} button. Press the Auto Setup button of the oscilloscope. To make accurate measurements, it is desirable for the signal to occupy as much of the screen as possible. With automatic settings, the signal will no longer remain on the screen at the highest effective value of the message signal. This is avoided by pressing the CH 2 button (it must be yellow, to deactivate CH1 and Math press 1 and Math). From the buttons below the oscilloscope screen press the button which correspond to Adjust Coarse, so as to switch the option from Coarse to Fine (to select the desired option press the rotary button Intensity / Adjust) and, then, modifying the vertical deflection coefficient from the rotary knob, above the input connector of channel 2, until the signal occupies approximately 6 vertical divisions, similar to the below representations

The maximum and minimum peak-to-peak values of the modulated signal for each effective value of the message signal are measured. $2A_{\max}$ will be the interval $A_{\max} - (-A_{\max})$ in figure 2.a), and $2A_{\min}$ will be interval $A_{\min} - (-A_{\min})$ in the same figure. In this first case, the effective value of the message signal is 0.3 V. For the measurement of $2A_{\max}$ press the Cursor button, switch from the button corresponding to the Source option until CH2 is reached (the button under the display of the corresponding oscilloscope Source and place the two cursors (using the Intensity/Adjust rotary knob just activated) at the maximum, respectively, the minimum value of the signal. To select the cursor you want to move, select Y1 or Y2 from the second button below the screen (from left to right) and press the Intensity/Adjust rotary knob to activate the cursor. The value indicated by ΔY (value taken in module) represents the $2A_{\max}$. Move the cursors properly to measure $2A_{\min}$ and read the value indicated by ΔY .

Amplitude modulated signals with harmonic carrier signal

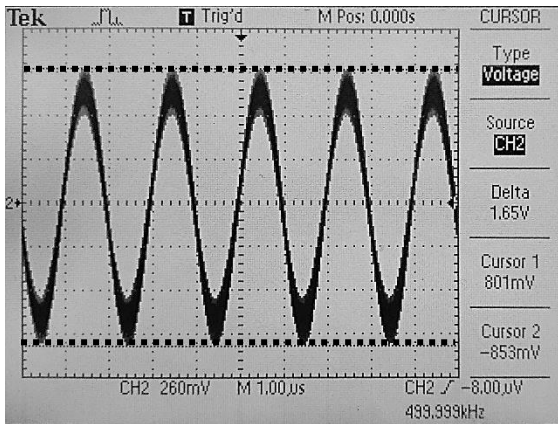

Measurement of $2A_{\max}$

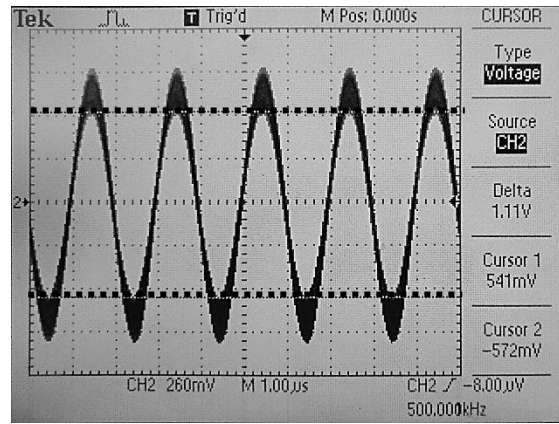

Measurement of $2A_{\min}$

Repeat these measurements for the rest of the effective values of the message signal. Relation (7) can be rewritten as follows:

$$m = \frac{2A_{\max} - 2A_{\min}}{2A_{\max} + 2A_{\min}}$$

After filling in the table, the waveform of the modulated signal can be observed as follows: press Auto setup, bring the horizontally deflection coefficient to $50 \mu\text{s}/\text{div}$ from the SEC/DIV rotary knob (in the Horizontal section) and press the RUN/STOP button. The message signal can be observed in the envelope of the carrier signal, similar to figure 2.a).

Table 2. Determination of the modulation index for the AM signal in the time domain

A_M [V _{rms}]	$2A_{\max}$ [V]	$2A_{\min}$ [V]	m	m [%]
0,3				
0,5				
0,7				
0,9				

Draw the waveform of the AM signal for all the effective values (given in Table 2) of the message signal.

Change the generated waveform (triangular and then rectangular), adjust the effective value to 0,5 V and display in similar mode the waveform of the modulated signal. Draw these two waveforms.

Amplitude modulated signals with harmonic carrier signal

C) The measurement of the bandwidth occupied by the AM signal, B_{MA} , using the spectrum analyzer

It will be considered that only the components with amplitudes greater than 1% of the amplitude of the component corresponding to the carrier signal form the bandwidth of the AM signal.

Reconnect the output of the modulated signal generator (OUTPUT) to the input of the spectral analyzer (RF INPUT 50 Ω). Adjust the SPAN parameter of the analyzer to 5 kHz/div by pressing the SPAN button and using the rotary knob to select the desired value of the possible ones. Adjust the carrier signal level (OUTPUT LEVEL indication on the modulated signal generator– the operation was described above) such that the spectral component at the 500 kHz frequency has a level of 0 dBm measured with the analyzer by pressing the MKR button, entering the value 0.5 and then pressing the MHz button (the condition should be met without the need for changes. Change if needed).

The effective value of the harmonic message signal is adjusted from the function generator to a value greater than or equal to 0.3 V (the condition should be met without the need for changes. Change if needed).

The components with amplitudes greater than 1% of the amplitude of the carrier, under the present conditions ($A_0 = 0$ dBm) are those components greater than -40 dBm. According to figure 3.b) it makes sense to measure the level of the components placed on the $F_0 \pm k \cdot f_0$ frequencies, where k is an integer and, in this case, $F_0 = 500$ kHz, $f_0 = 5$ kHz. It is recommended to measure and write the levels of the components corresponding to the frequencies given by $F_0 \pm k \cdot f_0$ from $k = 0$ to positive values up to the occurrence of 3 consecutive components with levels below -40 dBm, then resume the measurements at the frequencies given by $F_0 \pm k \cdot f_0$ from $k = -1$ to negative values up to the occurrence of 3 consecutive components with levels below -40 dBm. The bandwidth will be given by the difference of the spectral components frequencies with maximum, respectively, minimum frequency which have the level higher than -40 dBm.

Amplitude modulated signals with harmonic carrier signal

Compare the bandwidth of the modulated signal with the bandwidth of the message signal B_m (the bandwidth of a sinusoidal signal with frequency equal to 5 kHz, notion assimilated in the first laboratory).

D) The bandwidth of the amplitude modulated signal generator is measured

The amplitude of the carrier signal is set such that the amplitude of the spectral component situated on carrier frequency, $F_0 = 500$ kHz, to be 0 dBm (the condition must be fulfilled without any adjustments. If necessarily make the adjustment). Set the message signal frequency to $f_m = 5$ kHz (the condition must be fulfilled without any adjustments. If necessarily make the adjustment). It is desired to obtain a modulation index of 30%, meaning the level of the side components from the amplitude spectrum (on frequencies 505 kHz and 495 kHz) to be -16.47 dBm.

Justification: Knowing that $A_{k,ef} = \frac{m \cdot A_{0,ef}}{2}$, $k = \{-1,1\}$, $A_{0,ef} = 0.2236$ [V], $U_{ref} = 0.2236$ V and that desired modulation index is 30% (or 0.3) results:

$$A_{k,ef} \Big|_{\text{dBm}} = 20 \lg \left(\frac{A_{k,ef}}{U_{ref}} \right) = -16.47 \text{ dBm}, k = \{-1,1\}.$$

For this, using the marker of the spectral analyzer (MKR) the spectral component level at 505 kHz is measured and the effective signal value is changed by pressing the AMPL button of the function generator and changing the value using the rotary knob until the level measured with the analyzer is the one you want.

The frequency of the message signal is changed by pressing the FREQ button of the function generator, enter the desired value and press the kHz / Vrms button as shown in Table 3 until the amplitudes of the side components A_{-1} and A_1 measured with the spectrum analyzer (changing the frequency at which the measurement is made by pressing MKR and entering the new value), become smaller with 3 dBm than the value at which it was started at $f_m = 5$ kHz (-16.47 dBm), i.e. -19.47 dBm. The appropriate frequency of the message signal displayed on the function generator is f_M . The maximum bandwidth of the AM signal, given by the modulated signal generator, is $B_{MA} = F_{1M} - F_{-1M}$, where F_{1M}

Amplitude modulated signals with harmonic carrier signal and F_{-1M} are the frequencies corresponding to the components with the levels A_{-1} and A_1 equal to the level sought (≈ -19.47 dBm).

Table 3 Bandwidth determination of the modulated signal generator

F_M [kHz]	5	7	9	11	15	...	$F_M =$
F_1 [kHz]	505	507	509				$F_{1M} =$
A_1 [dBm]	-16.47						$A_{1(-3\text{dBm})} \cong -19.47$
F_{-1} [kHz]	495	493	491				$F_{-1M} =$
A_{-1} [dBm]	-16.47						$A_{-1(-3\text{dBm})} \cong -19.47$

E) The spectral components of the AM signal of a rectangular message signal with duty cycle 50%, frequency $f_0 = 5$ kHz and amplitude $A_m = 2 V_{\text{rms}}$ are measured.

The waveform of the modulator signal (message) is changed by pressing the Waveforms button of the function generator and then select the form of rectangular waveform by pressing the corresponding button below the screen. Adjust the effective value to 1 V by pressing the button which correspond to Amplitude, entering the desired value and pressing the Vrms button (the generator is designed to deliver the signal with the parameters displayed on the screen in a 50 Ω load.) As its output impedance is of 50 Ω , a voltage divider is formed, consisting of the output impedance and the load, which causes the signal to be 2 times smaller than the generated signal. In order to compensate this, the generator in this laboratory will always generate voltages which are doubled than the displayed ones. It is clear that if the load impedance has a high value - represented in this case by the input of the modulated signal generator, marked on it, equal to 10 k Ω - the voltage divider formed will introduce a negligible attenuation, and in the load will come almost all generated signal, which, we recall, is double than the one displayed. The user must take this into account and, in order to obtain an effective value of 2 V at the input of the modulated signal generator, an effective 1 V value must be set to the function generator. Some generators allow specification of load impedance - either High Z or 50 Ω - for proper display of values).

Amplitude modulated signals with harmonic carrier signal

Adjust the SPAN parameter to 20 kHz / div. Adjust the carrier signal level (OUTPUT LEVEL indication on the modulated signal generator - the operation described above at point A) so that the spectral component at the 500 kHz frequency has a level of 0 dBm measured with the analyzer by pressing the MKR key, inserting a value of 0.5 and pressing the MKR key (the condition should be met without the need to change it. If necessarily make the changes).

Table 4 is filled in. A_{-k} and A_k are the lower side components from the spectrum, respectively the upper ones, measured with the spectrum analyzer. All spectral components with amplitudes greater than -40 dBm (until at least 3 consecutive components with lower levels then -40 dBm) are measured.

Table 4 Measurement of side spectral components for a AM signal with rectangular message signal

k	F_{-k} [kHz]	$A_{-k,ef}$ [dBm]	$A_{-k,ef}$ [V]	F_k [kHz]	$A_{k,ef}$ [dBm]	$A_{k,ef}$ [V]
1	495			505		
2	490			510		
...						

F) The bandwidth, B_{MA} , of the AM signal from the point E) is determined taking in consideration that in the bandwidth there are only the components with the levels higher then -40 dBm according with the instructions from point C).

G) The first k spectral components of the message signal are measured, where k take the values from Table 4.

As this signal has a frequency of 5 kHz, it cannot be measured with the spectral analyzer, so use the oscilloscope as a spectral analyzer.

Connect the function generator (MAIN output) directly to the oscilloscope (CH2 input) without using the modulated signal generator. Press the Auto Setup button, press the Math Menu button, select Operation - FFT, Source – CH2. Change from the rotary knob (in the Horizontal section) SEC/DIV so that as many periods as possible enter the screen (5 ms/DIV). Then activate Hz/div from the corresponding button below the oscilloscope display and set 20 kHz using the SEC/DIV rotary knob from the Horizontal section.

Amplitude modulated signals with harmonic carrier signal

The cursors are used to measure component levels, noted $A_{k,p}$: Cursor key is selected, Source - Math, and the corresponding button to Y to activate the cursors to measure the level and use the rotary knob Intensity/Adjust to move the cursors and take measurements. Values are read from the active cursor Y1 or Y2 (at the bottom of the screen you can see which cursor is active). Attention, the spectral components of the studied rectangular signal are placed at frequencies given by $k \cdot 5$ kHz. You can change the cursor type to Type - Frequency to first identify the measurement components. The measured values are written on the Table 5. The oscilloscope has $U_{ref} = 1$ V, and the spectral analyzer has $U_{ref} = 0.2236$ V. Calculate the partial modulation index by studying the Figure 3.

Table 5. Partial modulation index determination

k	$A_{k,p,ef}$	$\frac{A_{k,p,ef}}{A_{1,p,ef}}$	$\frac{A_{-k,ef}}{A_{-1,ef}}$	$\frac{A_{k,ef}}{A_{1,ef}}$	m_{-k}	m_k
1						
2						
...						

H) The points E), F) and G) are repeated for a triangular message signal (DUTY=50%), with frequency $f_0 = 5$ kHz and effective value $A_m = 1.2$ V .

I) With the results from table 2 the characteristic of the modulator is drawn, $m = f(A_m)$. The K_A slope of this characteristic is determined.

J) The data processing required to fill in table 1 is performed and the four amplitude spectra are plotted.

K) With the help of the tables 1 and 2, table 6 is filled in.

In table 6, P_1 is the power calculated with the relation (9), and P_2 is the power calculated with the relation (12). X_{1ef} and X_{2ef} are obtained by using the relations (10), respectively (13). The useful powers P_{U_1} , P_{U_2} are calculated with the relations (11), respectively (14). On column A_m were written the values

Amplitude modulated signals with harmonic carrier signal which arrived in the load (at the input of the modulated signal generator). On the function generator were set the values at half. The causes were explained at point E).

Table 6. The calculation of the AM signal powers

A_m [V]	P_1 [mW]	P_2 [mW]	X_{1ef} [V]	X_{2ef} [V]	P_{U_1} [mW]	P_{U_2} [mW]	$\frac{P_{U_1}}{P_1}$	$\frac{P_{U_2}}{P_2}$
0,3								
0,5								
0,7								
0,9								

L) The normed amplitude spectra are plotted $\frac{A_k}{A_0}$ and $\frac{A_k}{A_1}$ depending on frequency, for the AM signal, respectively the $\frac{A_{k,p}}{A_{1,p}}$ for the message signal.

M) With the help of table 5, table 7 is filled in.

In table 7, P_1 is the power calculated with the relation (15), and P_2 is the power calculated with the relation (18). X_{1ef} and X_{2ef} are obtained using the relations (16), respectively (19). The useful powers P_{U_1} , P_{U_2} are calculated with the relations (17), respectively (20). The effective values used for power calculation are obtained using the relation (21).

Table 7

P_1 [mW]	P_2 [mW]	X_{1ef} [V]	X_{2ef} [V]	P_{U_1} [mW]	P_{U_2} [mW]	$\frac{P_{U_1}}{P_1}$	$\frac{P_{U_2}}{P_2}$

N) The M) point is repeated for the signal from point H).

4. Preparatory questions

a) Draw the amplitude spectrum of an AM signal defined by the relation:

$$x_{MA}(t) = 2 \left[1 + 0.3 \cos \left(2000\pi t + \frac{\pi}{2} \right) \right] \cos(6\pi \cdot 10^6 t), \text{ knowing that } A_m = 1 \text{ V}.$$

b) Is it possible to correctly demodulate the message signal from the AM signal given by the expression $x_{MA}(t) = 3[1 + 1.1 \sin(1000\pi t)] \cos(2\pi \cdot 10^6 t)$? Justify.

c) A carrier signal with amplitude 5 V and frequency 100 kHz is modulated in amplitude by a harmonic message signal with the frequency 1 kHz, and the modulation index is 0.5. Write the AM signal expression.

d) Can be realised the modulation between a rectangular message signal with a duty cycle of 25 % and frequency 200 kHz and a harmonic carrier signal with the frequency 13 MHz? Justify.

e) How much is the modulation index, m_1 , if $A_1 = -9 \text{ dBm}$, $A_0 = 0 \text{ dBm}$ and $U_{ref} = 0.2236 \text{ V}$?

f) Let it be an AM signal formed by a harmonic message signal and a harmonic carrier signal. With the oscilloscope the $A_{\min} = 0$ is measured. How much is the modulation index?

g) Let it be an AM signal formed by a harmonic message signal and a harmonic carrier signal. With the oscilloscope the $2A_{\min} = 3 \text{ V}$ and $2A_{\max} = 6 \text{ V}$ are measured. How much is the carrier amplitude in the absence of the message signal, A_0 ?

h) On the amplitude spectrum of an AM signal are measured the next values $A_0 = 0 \text{ dBm}$, $A_{-1} = A_1 = -9 \text{ dBm}$, $A_{-2} = A_2 = -25 \text{ dBm}$. Knowing that $U_{ref} = 0.2236 \text{ V}$, let's calculate the AM signal power.

i) On the amplitude spectrum of a AM signal (harmonic message signal, harmonic carrier signal) is measured $A_0 = -0.5 \text{ dBm}$. Knowing that the modulation index is 35% and $U_{ref} = 0.2236 \text{ V}$, let's calculate the AM signal power.

Amplitude modulated signals with harmonic carrier signal

- j) Let it be an AM signal formed from a harmonic message signal with the frequency equal to 10 kHz and a harmonic carrier signal with the frequency equal to 1 MHz. How much is the bandwidth of the AM signal?
- k) Let it be 3 message signals x_1 , x_2 and x_3 . The bandwidth of the x_1 signal is 50 kHz, The bandwidth of the x_2 signal is 300 kHz, and the bandwidth of the x_3 signal is 5 kHz. There are 3 harmonics carrier signals x_{p1} , x_{p2} and x_{p3} with the frequencies 10 MHz, 10,32 MHz and 10,38 MHz. Combine the message signal with the correct carrier signal in such a manner in which all AM signal resulted are sent in the same time on the same channel.

5. Questions

- a) How the ideal characteristic, $m(A_m)$, must look like and what significance has the deviation from the ideal form?
- b) What features of the oscilloscope can influence the precision of measuring the modulation index?
- c) How can you determine the characteristic of an AM modulator using only a peak voltmeter?
- d) How it can be explained the value of the bandwidth of the AM signal generator measured at point E)?
- e) How it can be determined the characteristic of an AM modulator using only one effective voltmeter?

6. Applications

- a) When an oscilloscope is used to measure an AM signal, it is found: $A_{\max} = 18 \text{ V}$, $A_{\min} = 2 \text{ V}$. Its effective value is required.
- b) When measuring with the spectrum analyzer an AM signal, it is found that the level of the carrier is 20 dB larger than the side components. It is required to determine the modulation index, m .
- c) An AM signal is generated using $A_0 = 1 \text{ V}$, $A_m = 0,5 \text{ V}_{\text{rms}}$, $F_0 = 800 \text{ kHz}$, $f_m = 10 \text{ kHz}$. Determine the modulation index using the spectrum analyzer.
- d) The same problem using the oscilloscope. Determine the slope of the modulator characteristic, K_A . Measure the spectral components and plot the amplitude spectrum of the signal.